

FORCE MAIN DIAMETER	GRAVITY SEWER DIAMETER
1 1/2" - 3"	6"
4"	8"
6"	8"
8"	10"
10"	12"
12"	15"

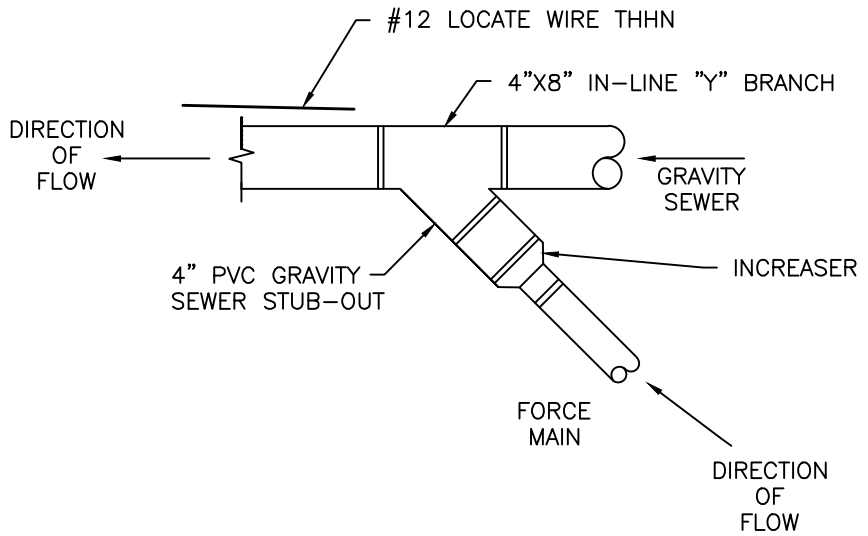
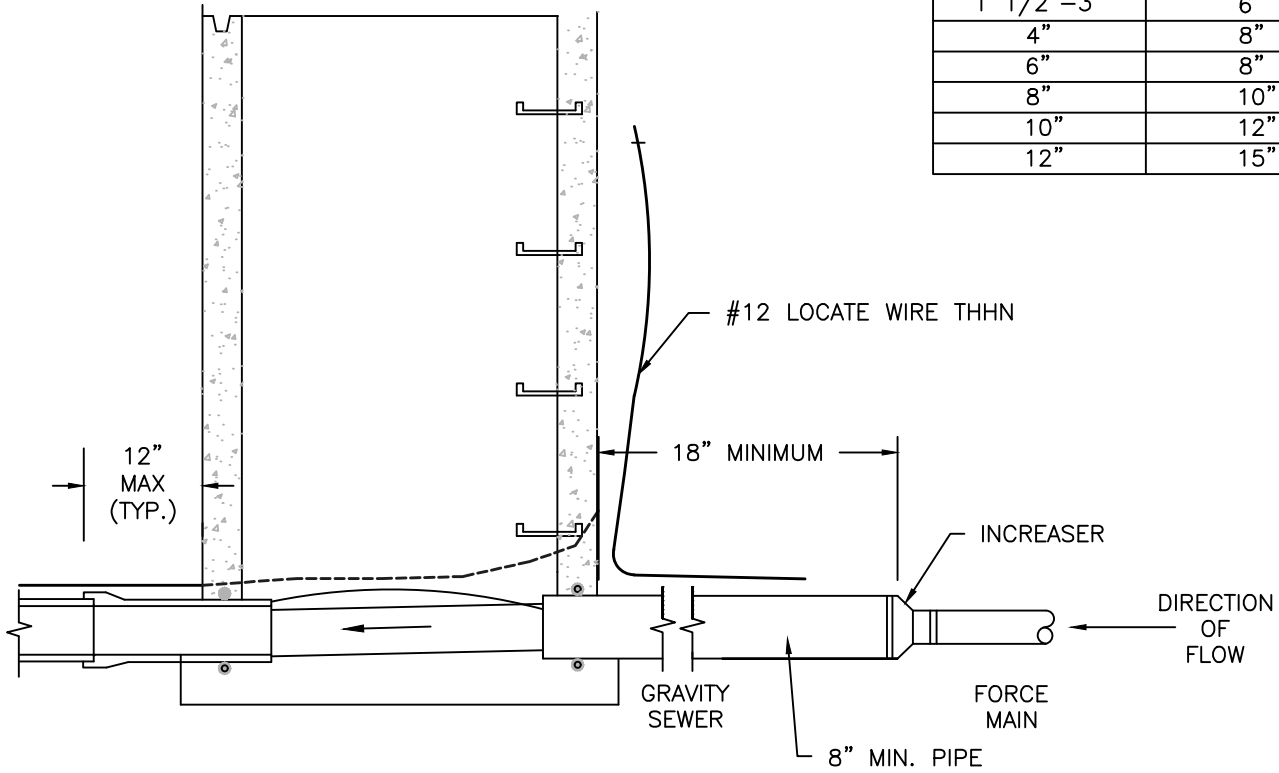

DETAIL NO.:

BSWSD:  
27-11

**BIG SKY WSD 363  
STANDARD DRAWING**

SCALE:  
NONE

**TYPICAL FORCE MAIN  
CONNECTION TO GRAVITY  
SEWER MAIN**

DATE: FEBRUARY 2010  
LAST REVISION: DECEMBER 2004  
CROSS REFERENCE WITH: N/A